

Illuminate Progress. Guide the Night.

Purpose-built for urban infrastructure and car park environments, this advanced street light delivers high-performance illumination with precision optics and robust thermal management.

Optimized for safety, energy efficiency, and long-term reliability, it ensures consistent visibility in low-light conditions—enhancing security and operational functionality after dark.



4.5 M & 6 M
Poles
NOW available

3 Pin NEMA with
shorting cap



Item No.	Size(mm)	Power selectable	Lumen Output	CRI	Colour Temp	Dimmable
STL1200	694 L x 336 W x 73 H	100W 150W 200W	15,000lm 22,500lm 30,000lm	>80Ra	5000K	NON-DIM

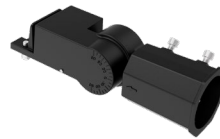
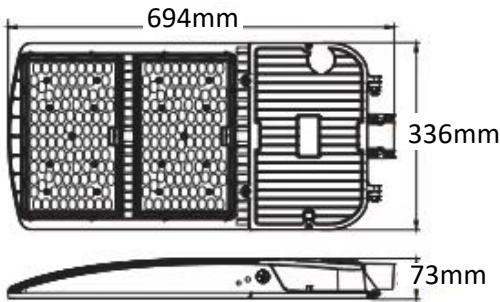

Type A



Type B



Type C



Type D



Photocell



Illuminate the City with Next-Gen LED Street Lighting — engineered by H3NZ for safer, smarter urban environments.

Key Features:

- High-Lumen Efficiency for Wide-Area Coverage
- Precision Light Distribution with Minimal Glare
- Ultra-Wide Voltage Range: 97–277V
- Multiple Wattage Options: 100W / 150W / 200W – ideal for diverse applications
- Energy-Saving LED Technology
- Durable, Weather-Resistant Construction

From residential streets and highways to parks and public spaces, our LED street lights deliver visibility, safety, and long-term performance—night after night.

www.H3NZ.co.nz

94 Station Road, Otahuhu
Auckland 1062

Sales Manager: **Bruce**@h3nz.co.nz
09-8694563

Trilogy Bracket installation menu

BRACKET A Slip Fitter Mount
(adjust from -90° ~ $+90^{\circ}$)

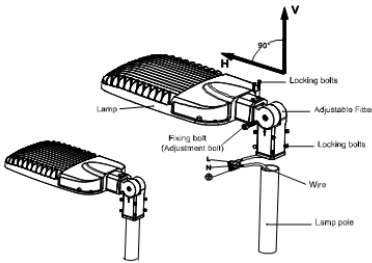

BRACKET B Adjustable Square Pole Mount
(adjust from -90° ~ $+90^{\circ}$)

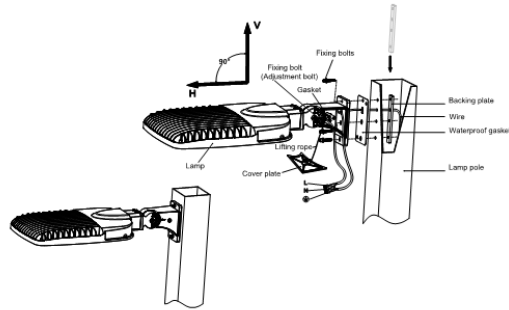

BRACKET C Adjustable Round Pole Mount
(adjust from -90° ~ $+90^{\circ}$)

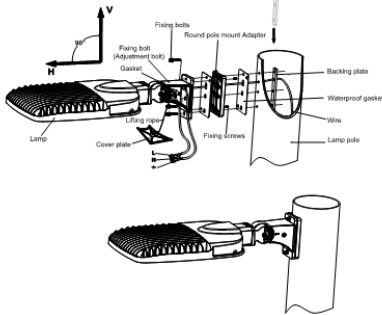

BRACKET D Fixed Square Pole Mount

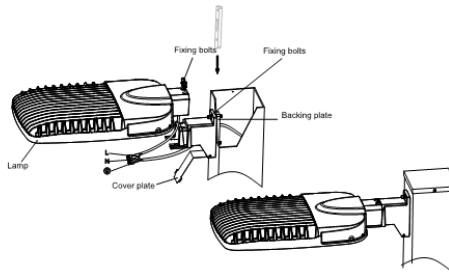

BRACKET E Trunnion
(adjust from -90° ~ $+90^{\circ}$)

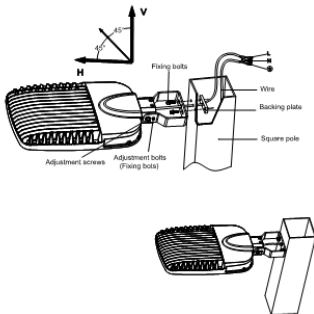

BRACKET F Wall mount
(adjust from -90° ~ $+90^{\circ}$)

